

特長

1. 電源電圧3.3V対応。
2. 25パルス、クリック、スイッチ付。
3. 軸は1軸及び2軸タイプが可能。
4. 接続方式が豊富、特注ハーネスも可能。
5. スイッチ出力は片側GND接続が標準、独立出力も可能。
6. シュミットトリガインバータ内蔵

Features

1. Supply voltage 3.3VDC available.
2. 25-pulse,with click and switch.
3. Single and dual shaft are available.
4. Various connecting to P.C.Board are possible.
5. Switch with JMP1 and without JMP1 are available.
6. With Schmitt trigger inverter.

(See circuit)

品番指定方法 How to order

EC208 [] 025 [] []

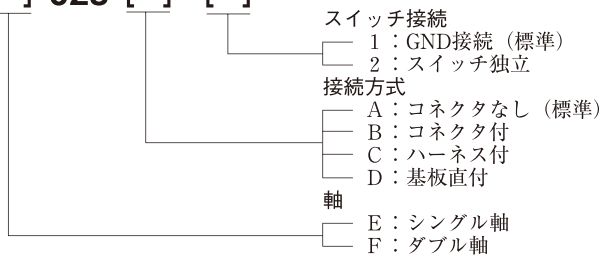

Switch
 1 : With JMP1 (Standard specification)
 2 : Without JMP1

Connection to p.c.board
 A : Lead wiring (standard specification)
 B : With connector
 C : With harness
 D : With header

Shaft
 E : Single-shaft
 F : Dual-shaft

仕様

ロータリエンコーダ	
電源電圧	DC3.3V ±5%
電源電流	30mA Max.
出力相	インクリメンタル
出力波形	矩形波
使用温度範囲	0~+60℃
保存温度範囲	-20~+80℃
分解能	25P/R
応答周波数	100Hz
耐久性	1,000,000
回転トルク	0.4 ± 0.3N·cm
クリック	あり
重量	20 g

プッシュスイッチ	
定格	DC12V 50mA
接触抵抗	200mΩ Max.
絶縁抵抗	100MΩ Min.
耐電圧	AC250V 1Minute
作動力	3~6N {306~612 g f}
作動量	0.7 ± 0.4m m
バウンス	10msec.
耐久性	1,000,000

Specifications

Rotary Encoder	
Supply Voltage	DC3.3V ±5%
Supply Current	30mA Max.
Output	Incremental
Output Wave	Rectangle Wave
Operating Temperature Range	0~+60℃
Storage Temperature Range	-20~+80℃
Resolution	25P/R
Frequency Response	100Hz
Rotational Life	1,000,000
Operating Torque	0.4 ± 0.3N·cm
Click	With Click
Weight (Approx.)	20 g

Push Switch	
Rating	DC12V 50mA
Contact Resistance	200mΩ Max.
Insulation Resistance	100MΩ Min.
Voltage Proof	AC250V 1Minute
Operating Force	3~6N {306~612 g f}
Travel	0.7 ± 0.4m m
Bounce	10msec.
Life	1,000,000

内部回路 Output circle

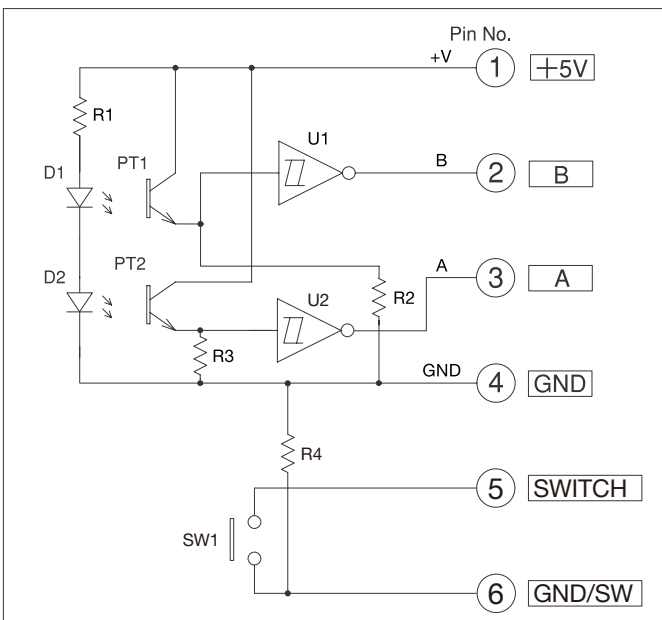

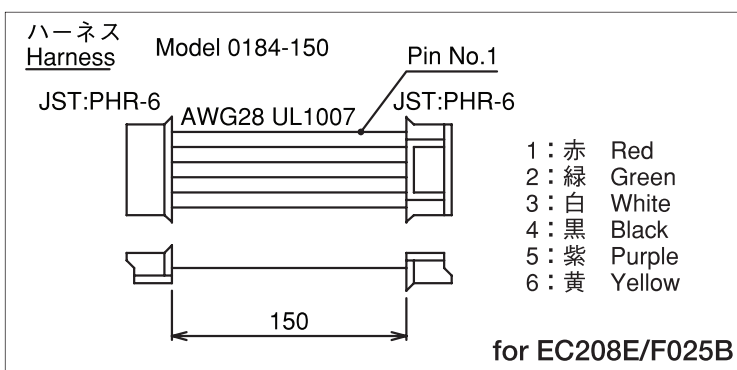
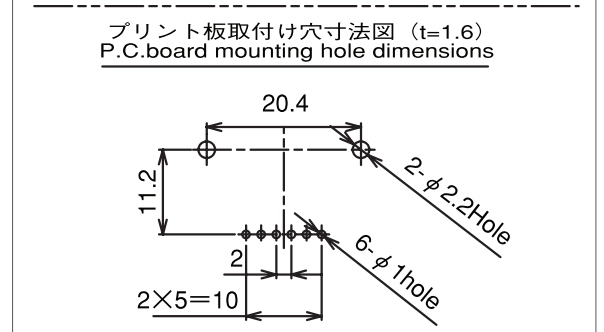
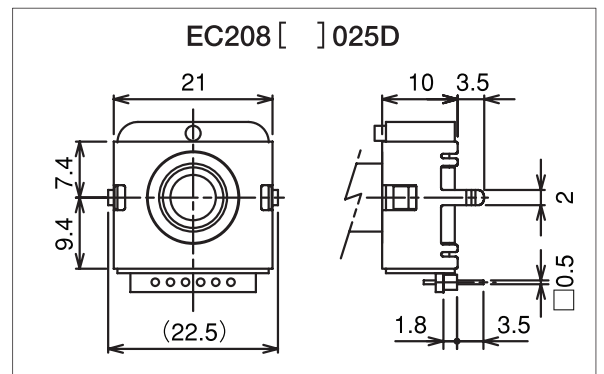
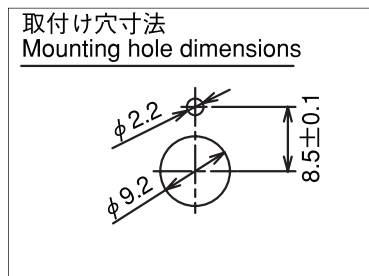
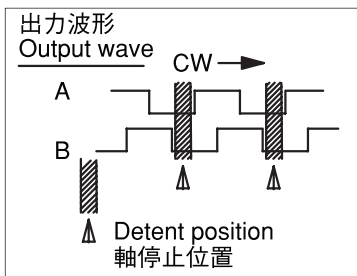
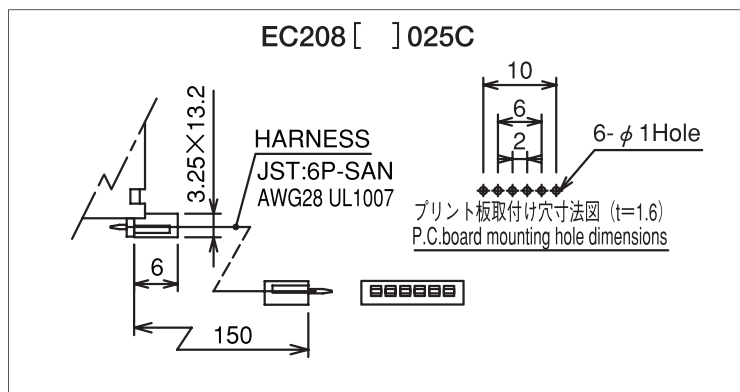
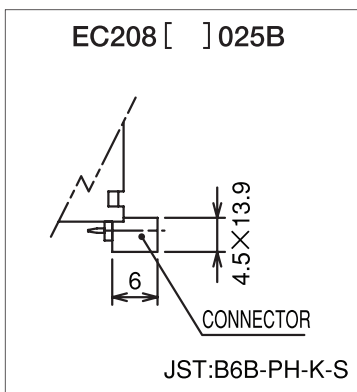
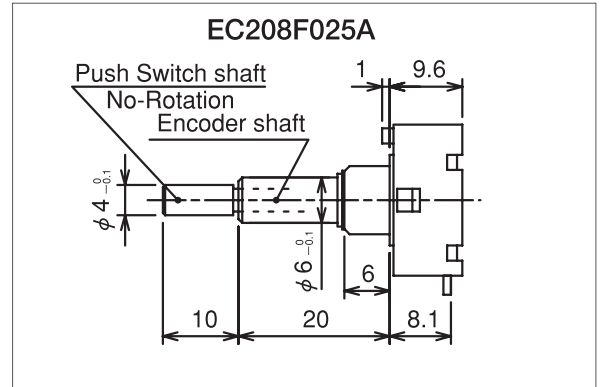
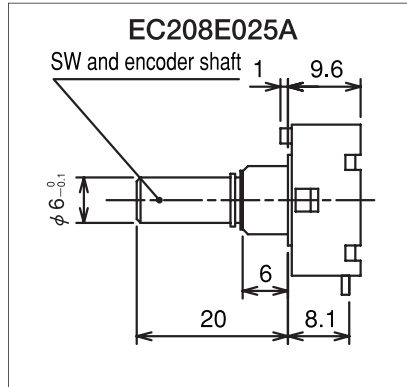
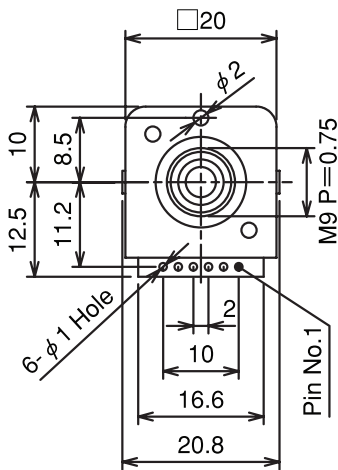

出力波形

- (1) CWではB相「0」の時A相が立ち上がり、CCWではB相「1」の時A相が立ち上がる。
- (2) 軸の停止位置ではA相、B相共に「0」です。

Output wave

- (1) CW : The phase A rises when the phase B is low level (0).
CCW : The phase A rises when the phase B is high level (1).
- (2) At the detent position both of phase A and B is low level (0).